



UL - Ex 4447  
FM - 0D8A9.AF  
ULC - CEx 1312  
USCG - 162.038/12/0

#### DESCRIPTION

Fike Carbon Dioxide cylinders are equipped with a cylinder valve assembly to hold the CO<sub>2</sub> agent in the cylinder until actuated. All Fike Carbon Dioxide cylinders are shipped from the factory as "Slave Cylinders" (Refer to Slave Valve sketch for details).

The cylinder valve assembly is a forged "brass" body. The actuation pressure required to open the valve is 100 to 110 psi (689 to 758 kPa). All valves are equipped with a safety relief disc that will rupture if the cylinder pressure exceeds 3000 psi (20,685 kPa) and a pilot port that is utilized for two (2) purposes:

- Fill port for charging the cylinder
- Actuator port for both the manual/mechanical and electric release functions

The valve can be installed as a master valve by removing two (2) plugs and installing either the 12V DC or 24V DC actuation kit. For Marine applications, the slave configuration is converted to a master valve by installing the local lever actuator assembly. (Refer to Master Valve sketches for details).

#### OPERATION

Slave Valve Cylinder is actuated when CO<sub>2</sub> back pressure from the piping manifold enters through the valve discharge port sending pressure to the top piston chamber. Due to the greater surface area of the piston, the pressure pushes the main seal downward and allows the CO<sub>2</sub> to discharge through the discharge port into the piping system. (Refer to CO<sub>2</sub> Valve section view for details).

The Master Valve Cylinder is actuated when CO<sub>2</sub> pressure in the cylinder is sent to the top pressure port through the pilot port. (Ref. to Master Valve sketch for details).

#### SPECIFICATIONS

Materials:	Valve - Brass Pilot Port - Stainless Steel
Operating Pressure:	100 to 110 psi (689 to 758 kPa)

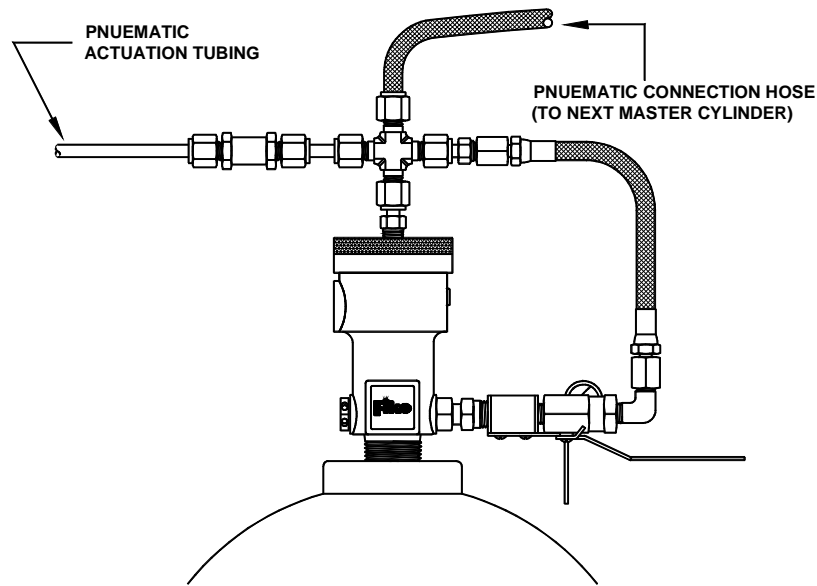
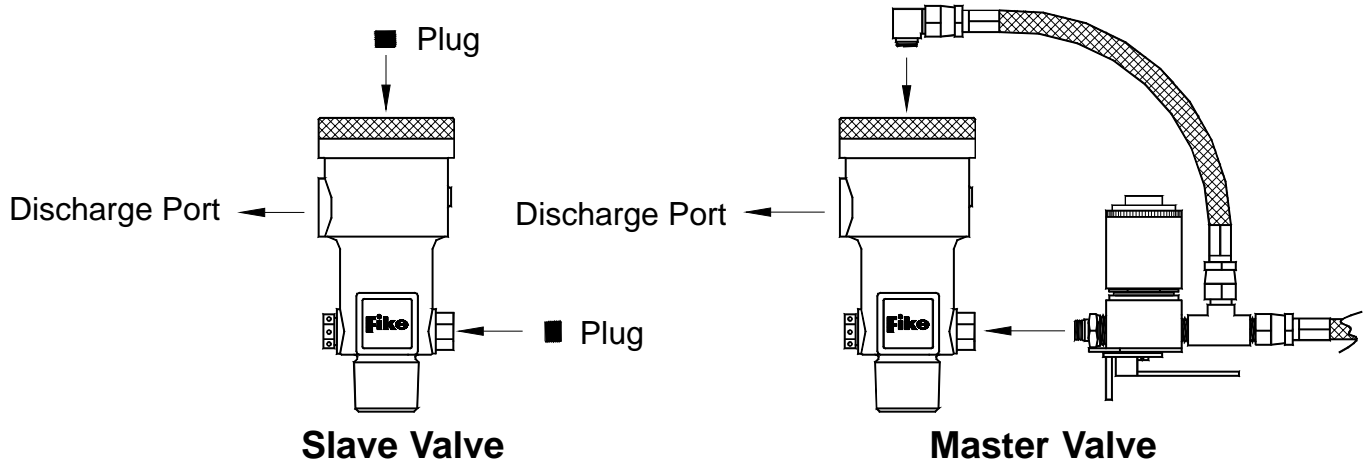

**Marine Master Valve**

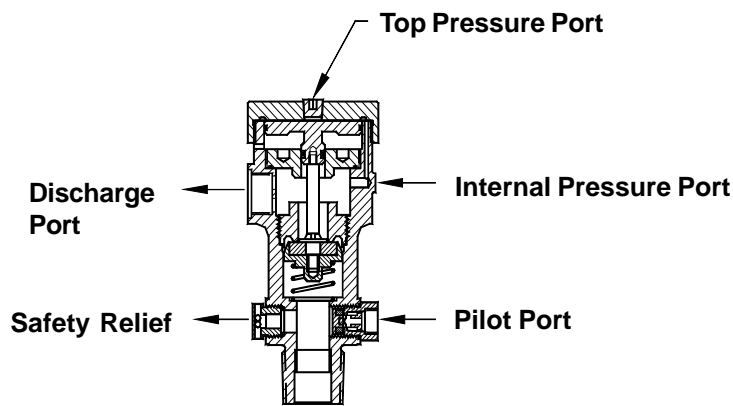

**CO2 Valve Section View**