

CO₂ Suppression Systems

HEADER SAFETY DEVICES

CATALOG NUMBER
E.1.08.01

C70-231
C02-1363

UL - Ex 4447
ULC CEx - 1312
FM - 3002238
USCG - 162.161/2/0 (HFC-227ea)
USCG - 162.038/12/0 (CO₂)

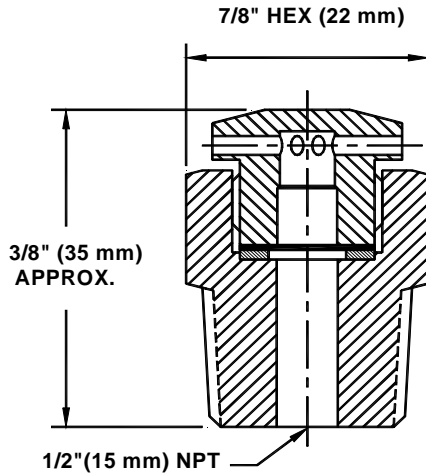

HEADER SAFETY RELIEF

APPLICATION

The header safety relief is a device used to relieve a high pressure build up in a closed section of piping. If actuation pressure is inadvertently trapped and, should an increase in temperature occur, it will cause the pressure to rise to a dangerous level, and the burst disc will rupture allowing the pressure to escape.

DESCRIPTION

The header safety is constructed of brass and is installed in a 1/2" (15 mm) NPT tee or coupling located in the closed section of piping. Should the pressure in a closed section of piping increase to a level of 2,650 to 3,000 psi, the disc will burst and allow the pressure to be vented safely to the atmosphere.

SPECIFICATIONS

Materials Brass Body
 Nickel Disc

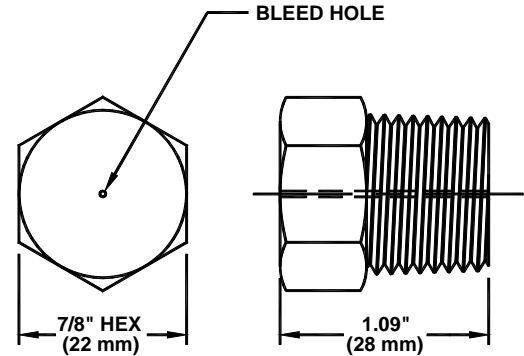

HEADER VENT PLUG

APPLICATION

The header vent plug is used to release a low pressure build-up that may occur in a closed piping system using time delays, selector valves or maintenance/stop valves. This pressure relief feature thus prevents pressure from building up to a level that will cause a system discharge.

DESCRIPTION

The header vent plug is constructed of brass and is installed in a 1/2" (15 mm) NPT tee, or coupling, located in the closed section of piping. The header vent plug continuously vents any trapped pressure to the atmosphere. During a system discharge, the vent hole will discharge an insignificant amount of CO₂ that does not affect system performance.

SPECIFICATIONS

Materials Brass

This page intentionally left blank