

CO₂ Suppression System

Architect and Engineering Specification

P/N C02-1360
C02-1361 (Approval Pending)

UL - Ex 4447
USCG - 162.038/12/0

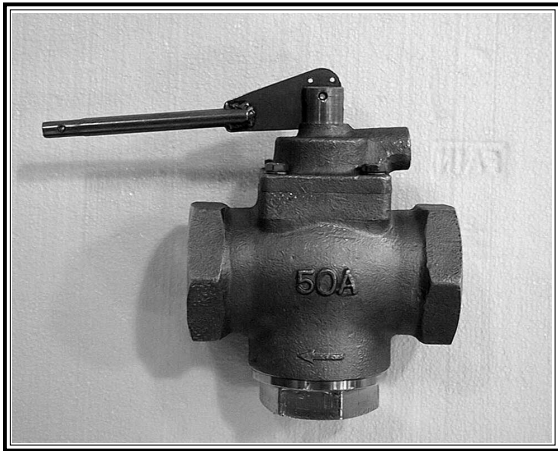

DESCRIPTION

The Stop/Selector valve serves two functions:

It provides the second step, Stop Valve function that helps to assure the safe release of CO₂ into the protected hazard. (Manual activation via a Latch Door Pull Box and stainless steel cable.)

As a Selector Valve, it directs the flow of CO₂ into a specific hazard area when protecting multiple hazards with a common CO₂ supply. (Pneumatic activation via a Remote Pneumatic Actuator Valve and piping connection.)

The Stop/Selector Valve should be located near the Carbon Dioxide cylinders, and shall be connected to the discharge piping or supply manifold that is connected to the discharge piping. Each Stop/Selector Valve has a flow direction arrow on the valve body that must point in the direction of flow to the affected hazard(s). The valve is a “differential pressure” type that blocks the flow of agent until activated. The Stop/Selector Valve can also be operated manually by operating the manual release lever located on top of the valve assembly.

SPECIFICATIONS

Part Number: C02-1360 – 1" NPT Valve
C02-1361 – 2" NPT Valve

Materials: Valve – Brass
Handle – Stainless Steel

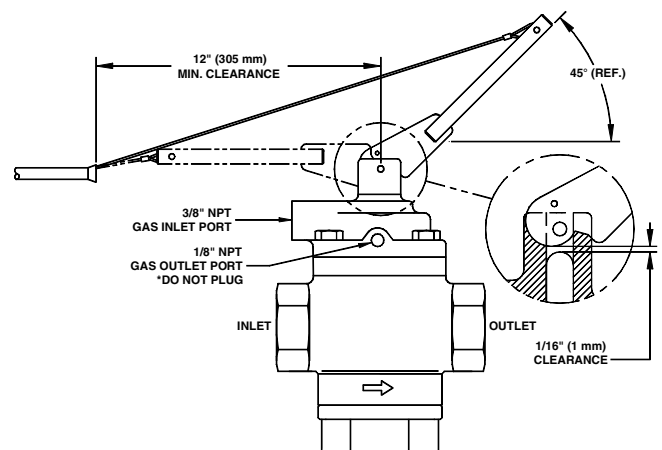

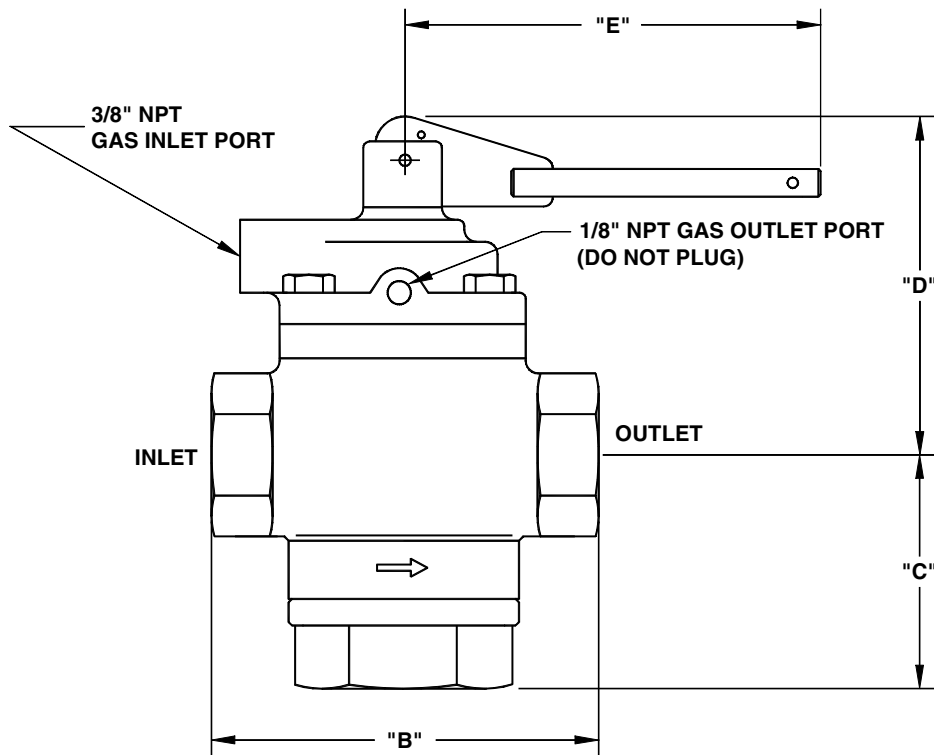

SELECTOR VALVE DATA					
Part No.	Size	Dim. "B"	Dim. "C"	Dim. "D"	Dim. "E"
C02-1360	1" NPT	4.33" (110 mm)	2.87" (73 mm)	4.29" (109 mm)	7.09" (180 mm)
C02-1361	2" NPT	6.69" (170 mm)	3.54" (90 mm)	5.31" (135 mm)	7.87" (202 mm)

* All dimensions are approximate