



HFC-227EA LIQUID LEVEL INDICATOR

DESCRIPTION

The Fike 70-1353 series Liquid Level Indicator is a simple manually operated device which provides a means to determine the Clean Agent liquid level in vertically mounted agent storage containers. Once the liquid level is determined, it can then be converted into pounds (kilograms) of Clean Agent present in the agent storage container. (Refer to Fike HFC-227ea Instruction Manual for Liquid Level Indicator (LLi), P/N 06-107.)



Liquid Level Indicator

Operation

A magnet equipped float moves with the liquid level along the unit stem. Level readout is obtained by simply removing the protective cap and pulling out a calibrated tape until magnetic interlock with the float is felt. With the tape in this position, the reading is obtained at the point where the tape emerges from the unit housing.

When the liquid level is determined, the reading is then located on a chart and the corresponding Clean Agent weight is read. Accurate readings can be obtained over a +40 to +90°F (+4.4 to +32.2°C) temperature range.

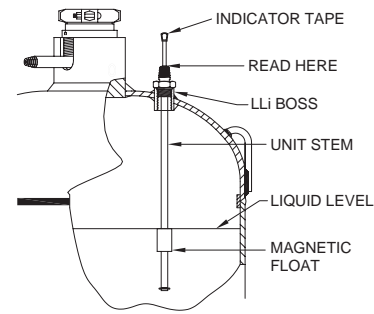

Features

- Reduced maintenance time - the weight of the agent in storage containers can be determined in a fraction of the time it would take to remove and weigh them.
- Continuous fire protection - use of the liquid level indicator does not require shutting down the Clean Agent System, thus affording uninterrupted fire protection.
- Field installation capability - the indicator can easily be installed in the field using a single wrench, as long as the container is empty and is equipped with a mounting boss.
- Compact - when not in use, the unit requires no more space than that required by the container.
- Flexibility - the flexible tape design allows the unit to be used in tight spaces that would otherwise hinder the use of a rigid indicator "stick".
- Availability - units are available for Fike container sizes of 100 lb. (44 liter) through 1000 lb. (423 liter) in both the modular and central storage type designs.

Construction

The Fike 70-1353 series Liquid Level Indicator housing and stem assembly is constructed of brass. The flexible indicator tape is constructed of steel with a yellow mylar coating. The indicator tape is calibrated in inches and centimeters.

The unit housing provides straight mounting threads with a static O-ring seal. The float is constructed of a special ECCO material for high pressure service. The cellular construction of the ECCO material allows the float to be solid and is not susceptible to water-logging, as hollow floats are if they develop a leak. The unit is provided with a plastic protective cap.

APPROVALS

- UL Ex4623
- FM 3002238
- USCG 162.161/2/0

Form No. C.1.05.01-2

AVAILABLE MODELS

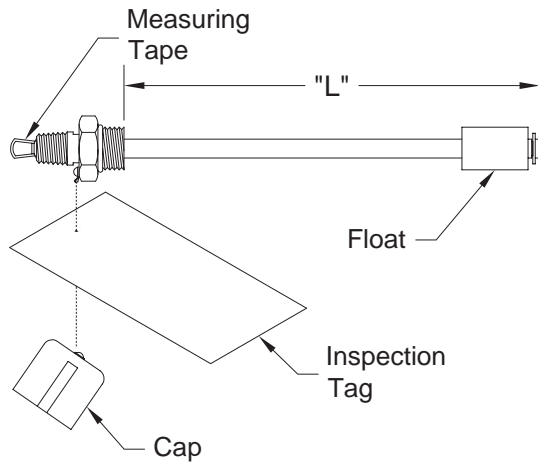

INDICATOR P/N	DIMENSION "L"	CONTAINER SIZE	CONTAINER P/N
70-1353-22	22" (381 mm)	100 lb (44 liter)	70-153
70-1353-11	11" (278 mm)	125i lb (51 liter)	70-041
70-1353-15	15" (381 mm)	215 lb (87 liter)	70-154/S70-154
70-1353-15	15" (381 mm)	215i lb (90 liter)	70-077
70-1353-24	24" (610 mm)	375 lb (153 liter)	70-155 / S70-155
70-1353-38	38" (965 mm)	650 lb "short" (267 liter "short")	70-156 / S70-156
70-1353-44	44" (1118 mm)	1000 lb (423 liter)	70-157 / S70-157

ARCHITECT AND ENGINEERING SPECIFICATIONS

Agent storage containers of 100 lb. (44 liter) capacity or more shall be provided with a reliable means, other than weighing, of determining the agent weight within the storage container during normal routine service.

The device used shall be a Fike 70-1353-xx series Liquid Level Indicator and shall not require any additional space when the container is installed.

Use of the indicator shall not require the Clean Agent System to be shut down, thus allowing uninterrupted fire protection during service intervals. Level indicators which are not factory installed shall be capable of being retrofitted in the field, with a single standard wrench, when the container is removed for recharge.

The level indicator tape shall be flexible to allow use in confined spaces. The unit housing shall be constructed of brass with straight mounting threads and a static O-ring seal. The float shall be of solid construction to eliminate the possibility of water logging to which hollow floats are susceptible. The float shall be equipped with a magnet which provides for a positive feel when the magnetic interlock is reached between the float and indicating tape.

When the level reading is obtained, the agent weight can be determined through the use of the chart or graph found in the Liquid Level Indicator Manual (P/N: 06-107). Accurate readings shall be capable of being obtained over a +40°F (+4.4°C) to 90°F (+32.2°C) temperature range.

